Limited Access Privilege Program (LAPP)
Exploratory Workgroup Survey Results
April 2008

Gregg Swanson
Graduate Student

LAP Program Exploratory Workgroup

- Established by the SAFMC in 2007 to investigate options for a Limited Access Privilege Program for the snapper grouper fishery in the South Atlantic
- Intended to assist the LAP Program Committee in designing a program to fit the specific needs of the South Atlantic
- Tasked to provide recommendations and explore possible benefits and drawbacks of a LAP Program in this region

LAP Program Exploratory Workgroup

- Adopted the following goal in designing a program to fit the needs of the South Atlantic region:

To refine a system whereby profitability, efficiency, fairness, and capacity of the commercial snapper grouper fishery are aligned with available yields from the South Atlantic ecosystem and which contribute to conserving healthy stocks and/or rebuilding overfished stocks consistent with the Snapper/Grouper FMP and Magnuson-Stevens Act

Purpose of LAPP Workgroup Survey

- To obtain feedback from Workgroup members in order to improve the interaction and communication between resource managers and resource users
- To ensure this management tool- incorporating a Workgroup in the early stages of developing a management plan- is utilized to its best ability

Scope

- Simple, eleven-question survey was mailed to each Workgroup member (17 total)
- Questions consisted of Likert scale (1-strongly agree, 5-strongly disagree) and yes/no type answers
- Workgroup members were asked to return the questionnaire in a self-addressed, stamped envelope by May 1, 2008
- Total of 15 out of 17 returned surveys
- 88% return rate

Question #1

- How would you describe your participation in the snapper grouper fishery?

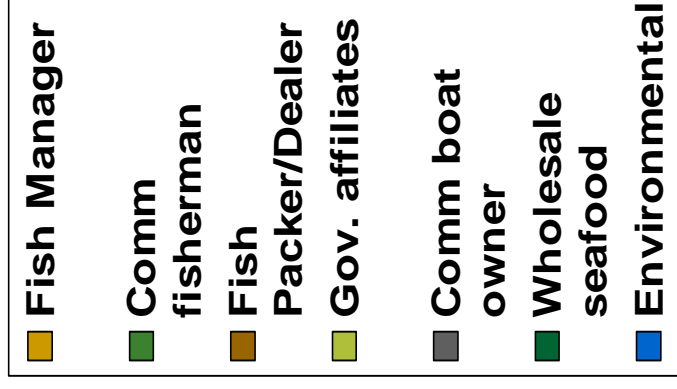
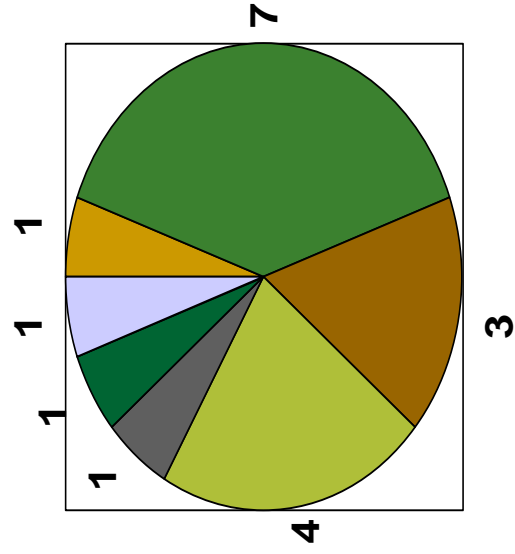

Question #2

- Do you think participation was rightly represented in the LAP Program Exploratory Workgroup?

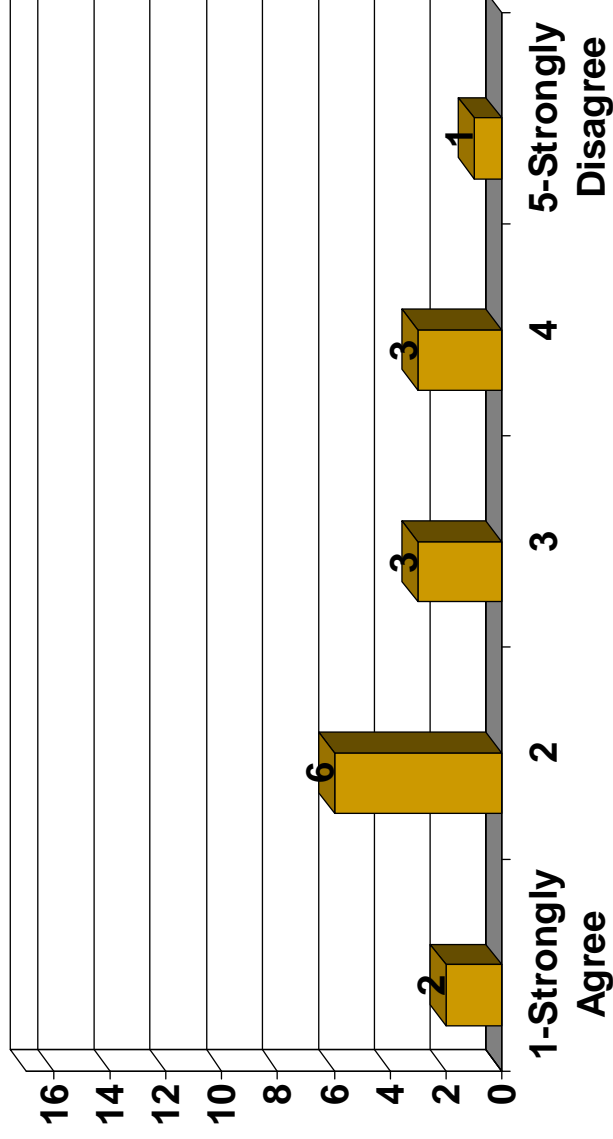

Comments- Question #2:

Do you think participation was rightly represented in the LAPP Exploratory Workgroup?

- “We were missing adequate representation from the long-line sector.”
- “This was an industry meeting, should not have had so much influence from Environmental Defense.”
- “Too few [representatives] from South Florida which has the most fishermen.”
- “There should have been more fishermen, less fish houses and less concentration on Environmental Defense.”
- “Recreational sector was unable to attend meetings, and therefore this sector was not represented.”
- “No, over 50% of the members were non-to-little dependent on the South Atlantic SNGR fishery.”
- “The Workgroup should be dominated by full-time commercial fishermen.”

Question #3

- Do you think other people/professions should have been placed on the LAP Program Workgroup that were not?

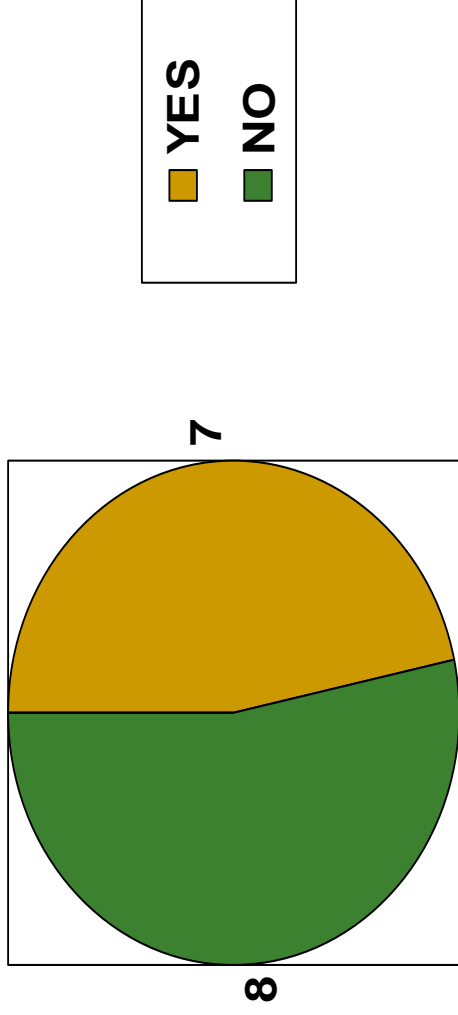

Comments- Question #3:

Do you think other people/professions should have been placed on the LAPP Workgroup that were not?

- More full-time commercial fishermen
 - Cultural Anthropologist
 - NMFS economist with total access to the records
 - NMFS legal department representative
 - Knowledgeable scientist
 - Sociologist
 - Universities/Researchers/Professors
 - Gulf Council member
 - Recreational angler
 - Long-liner
 - A Cuban fishermen from Miami area
-

Question #4

- Overall, do you think this management approach was more effective than the ordinary management approach?

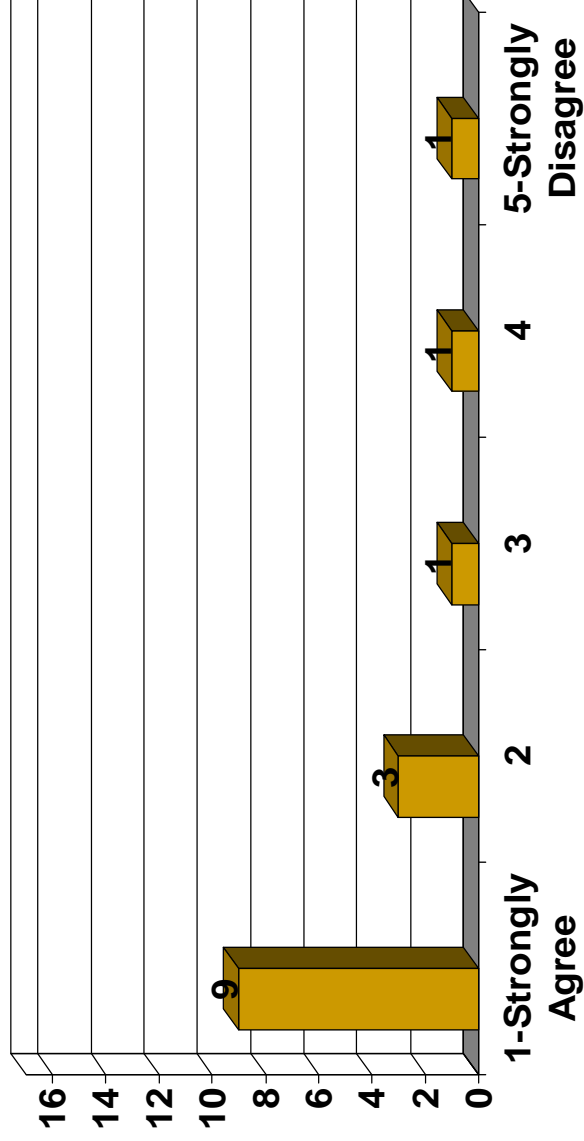

Comments- Question #4:

Overall, do you think this management approach was more effective than the ordinary management approach?

- “The workgroup process provides for more meaningful dialogue than do traditional public/stakeholder participation methods. It also encourages cooperation and communication.”
- “The exploratory workgroup takes up too much time. Too many fishing trips had to be missed in order to attend meetings. The people that need to be represented cannot afford to miss this much work.”
- “Without this group, there would never have been as much depth in all of our discussions.”
- “This approach was absolutely necessary due to the complexities of the topics and the amount of information to consider.”
- “There could have been more telephone work instead of meeting so often.”
- “Frequently, the meetings were slightly redundant and non-productive.”
- “Not more effective, but used together with the right people on the Workgroup, outreach, dealers, fishermen, and industry leaders is the right approach.”
- “The Workgroup is as close to co/management that we have experienced in the Council process. I strongly recommend using this foremost in the future for other management efforts.”

Question #5

- Do you think the amount and quality of research and outreach materials distributed to the Exploratory Workgroup was adequate to make informed decisions?

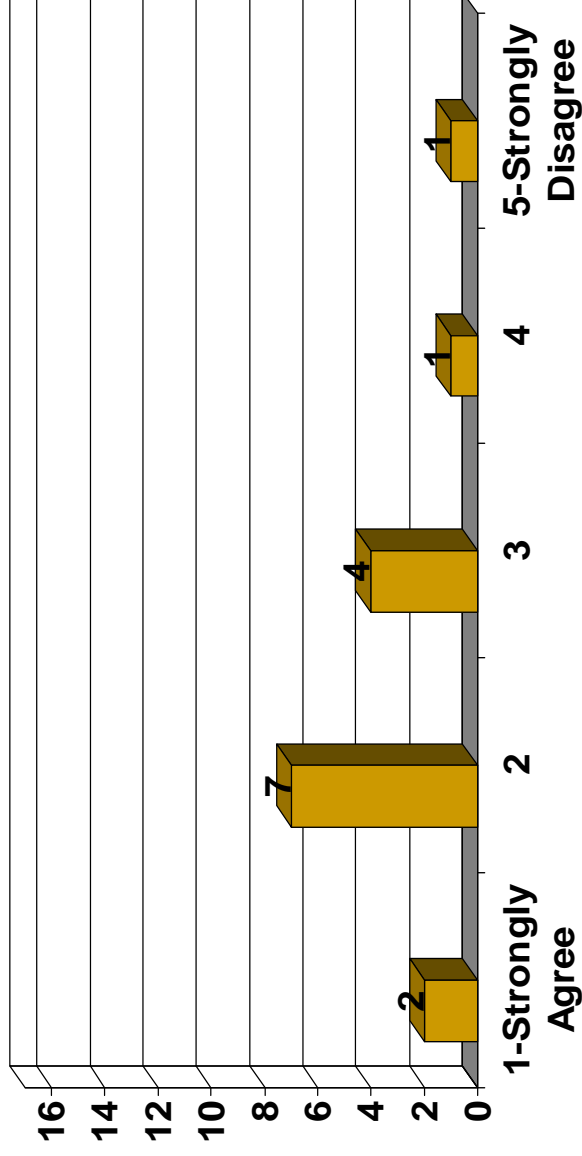

Comments- Question #5:

Do you think the amount and quality of research and outreach materials distributed to the Workgroup was adequate to make informed decisions?

- “Kate did an excellent job in bringing reference materials to the table.”
- “In general, the information was good. Probably could have used more info on alternative LAPP designs and how each design would affect fishermen.”
- “There were concerns about information concerning potential allocation. Some members needed exact numbers to make their decisions.”
- “The group could not get data back from NMFS in a timely manner to help the group on some issues.”
- “The quality of research compiled was great. But NMFS permit department struggled or failed to meet our request.”
- “It was difficult conveying the technical information to people outside the Workgroup.”
- “On the SAFMC level, yes; on NMFS level, no. There was tons of information that we asked NMFS to provide, and it didn’t happen.”
- “More data of the effects on this fishery- an economic analysis on the cost of doing business with increased cost of monitoring wasn’t presented.”

Question #6

- Are you satisfied with the effort and participation of the Workgroup members?

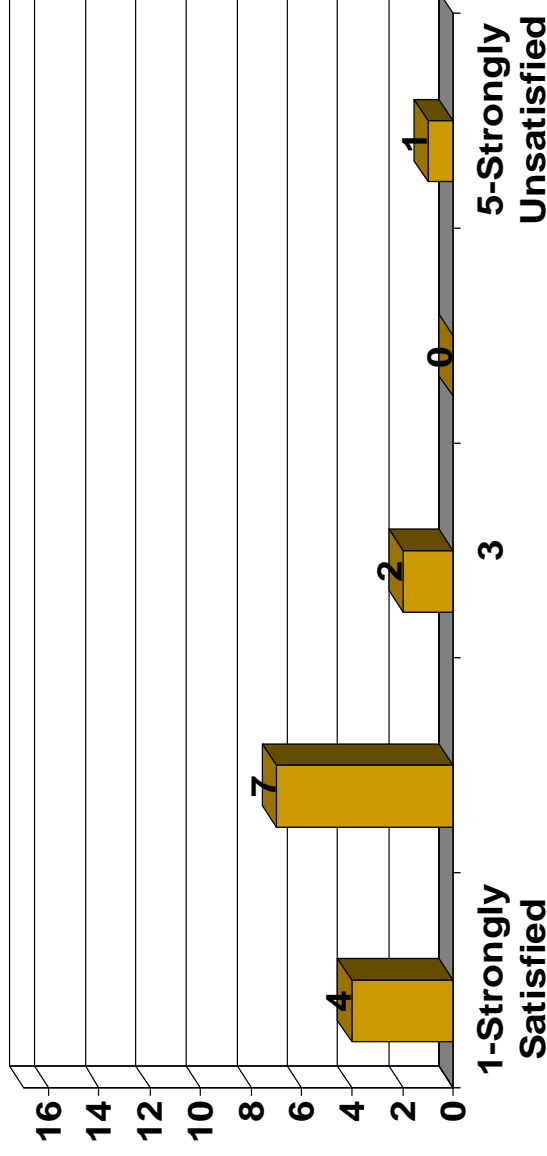

Note: One Workgroup member rated the effort of the Commercial fisherman as a 1, while rating the participation of fishing organizations a 4.

Comments- Question #6

Are you satisfied with the effort and participation of the Workgroup members?

- “No, with a thousand people’s investment’s, futures, and grocery money at stake, Workgroup members needed to look past their own needs. Regardless of what might be best for you or me, if a plan puts 75%-90% of the fishermen out of business, how can the vote against it be anything but 75%-90% against LAPPs?”
- “Overall, most Workgroup members approached the task at hand with an open mind and respected each others comments and opinions.”
- “There were some members that did not show up and others showed up but didn’t participate at the meetings.”
- “We did all that we could, considering that we did not have all the information.”
- “Satisfied, but with one exception, the environmental advocate was too intrusive with paid educational trips to Canada for other board members.”
- “Participation was uneven. Key members missed one or more meetings; several key members missed the last meeting in which recommendations were made.”
- “I would rate the participation of the true commercial fishermen on the Workgroup 1- very satisfied and the executive directors of fishing organizations a 4- unsatisfied. As the latter’s involvement was dominated by the ideas of their respective board of directors. They actually can’t act independently where actual fishermen can and do.”

Question #7

- Are you satisfied with the amount of effort the Council put forth to engage different stakeholders in the workgroup process?

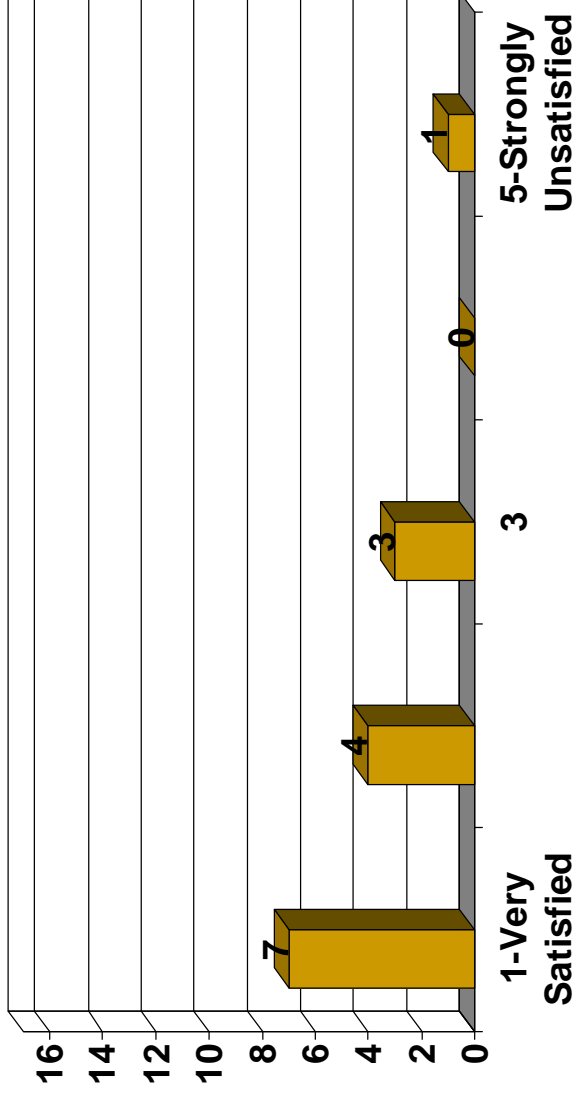

Comments- Question #7:

Are you satisfied with the amount of effort the Council put forth to engage different stakeholders in the workgroup process?

- “All fishermen present were fully engaged and productive in the process.”
 - “The staff was very committed to making the process work.”
 - “With EDF’s participation, sometimes it was unclear who brought in whom to speak at out meetings. I did really appreciate hearing from as many ‘experts’ as possible.”
-

Question #8

- Do you think the LAP Workgroup accomplished the tasks requested by the Council?

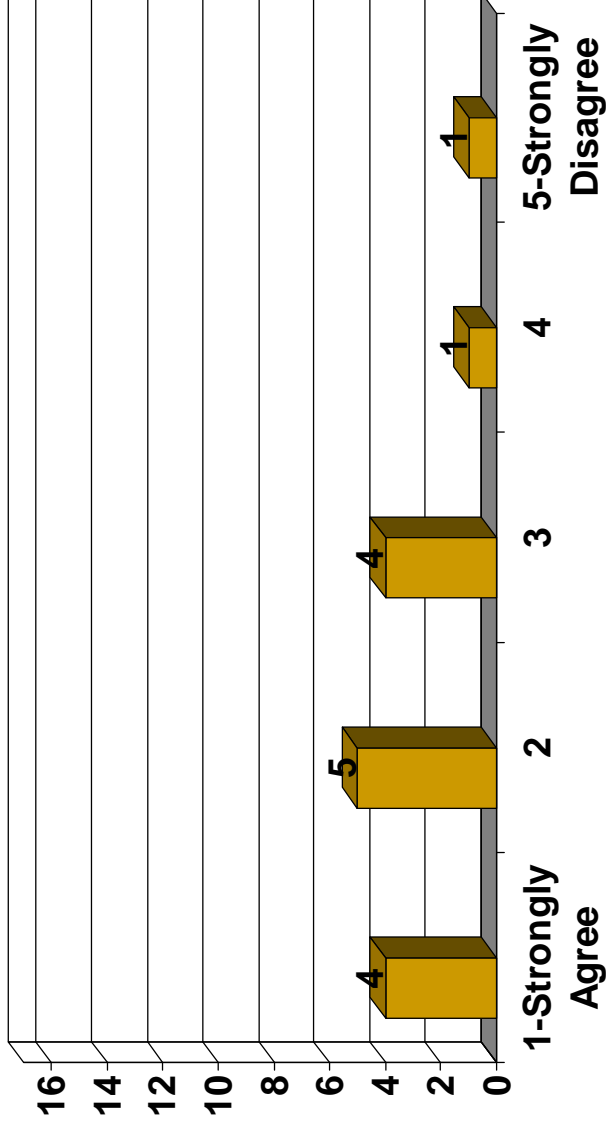

Comments- Question #8:

Do you think LAP Workgroup accomplished the tasks requested by the Council?

- “We tried, it was a very complicated task with many questions from the group at the end.”
- “Yes-No-Maybe. I don’t think the Council heard our recommendations.”
- “No. We had too little time to engage fishermen as to their options and opinions; therefore, we could not develop a fair and equal plan to carry the fishery into the future.”
- “Probably, but it really came down to money and change in a fishery and fishermen are stubborn.”
- “We accomplished the tasks to the best of our ability. However, we discovered that there were many more unanswered questions and information needs that ultimately hindered our ability to present a definitive ‘yes’ or ‘no’ recommendation about LAPPs at this time for this complex fishery.”
- “Not enough time! You can’t put together an effective IFQ program in 13 meetings!”
- “The Workgroup stopped short of developing clear options or developing a clear path for moving forward.”
- “Although we didn’t produce a fully finished product, we did give the Council a template of the most important aspects of a LAP program.”
- “To the extent we were able to-yes. It’s hard to make decisions when enormous uncertainties remain in question- recreational accountability, lack of monitoring program, federal money for LAPP implementation.”

Question #9

- Did you feel that you could voice your opinions in an effective way by serving on the Workgroup?

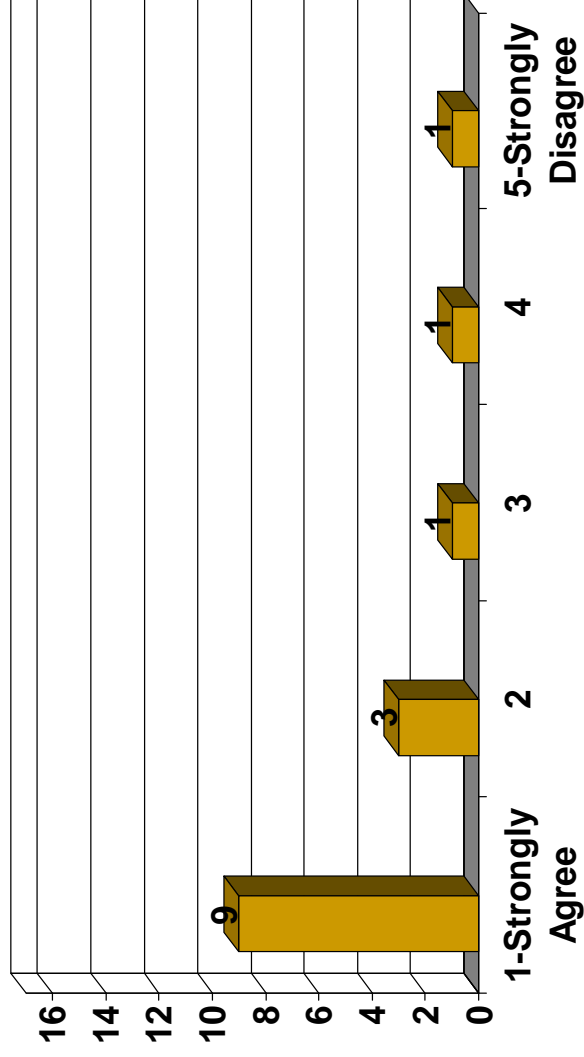

Comments- Question #9:

Did you feel that you could voice your opinions in an effective way by serving on the Workgroup?

- “I don’t think anyone on the workgroup held back any opinions they might have had. It was a very inclusive process to the extent that the audience was also allowed to comment on the program.”
 - “It was interesting in that we never knew whether individuals supported or opposed LAPPs.”
 - “The Workgroup process was very conducive to expressing opinions and sharing information.”
 - “I don’t know; I tried.”
 - “No. Lack of time and information.”
 - “The meetings were conducted in a fair and informal way which allowed all views to be expressed.”
-

Question #10

- Would you consider serving in another Workgroup like this one in the future?

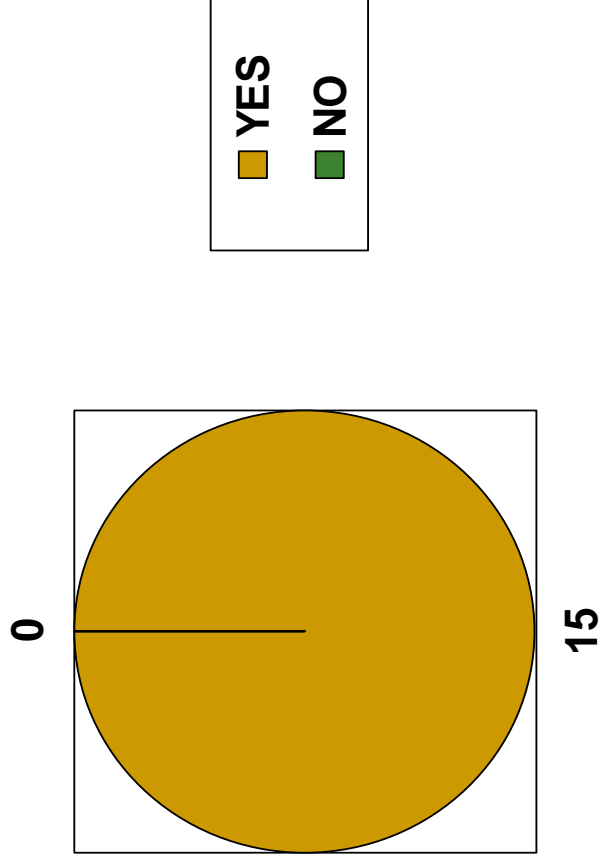

Comments- Question #10:

Would you consider serving in another Workgroup like this one in the future?

- “Only to be paid for my time and experience in the industry.”
- “Yes, with the knowledge I’ve gained through this experience. I believe some people feel I was representing them, so I would have to follow through.”
- “Yes, but reluctantly, because enforcement needs to devote its effort toward enforcing laws, not talking about them for six months.”
- “This was an extremely valuable experience that helped build communication networks between all stakeholders involved across the region.”
- “I have too much at stake to give up now.”
- “Would evaluate on a case-by-case basis. In general, conservation groups should have a seat at the table- there are times; however, where having a seat on the workgroup is not necessary.”
- “Yes, but not without some reservations.”

Comments- Question #11:

What recommendations do you have to improve the Workgroup process in the future?

- “Council should consider conservation groups as legitimate stakeholders and include a voting conservation seat.”
- “Council should not require consensus from the Workgroup because it provided some Council members with an excuse to do nothing.”
- “Workgroups are advisory- Council needs to give weight to Workgroups, but needs to assert more leadership when Workgroup doesn’t produce a consensus set of recommendations.”
- “Better use of voting process.”
- “Higher priority of NMFS and Council staff time and efforts.”
- “Develop the concept of directed sub-committees for specific issues.”
- “Make telecom possible.”
- “Reduce travel.”
- “Let’s get better science from the fishermen, not environmentalists.”
- “Identify data analysis needs early in the process in order to identify the realistic capabilities of the analysis, data availability, and timeframe for which to complete the analysis.”

Comments Continued- Question #11:

Recommendations for future Workgroups

- “Consistent participation of NMFS staff and perhaps have legal counsel expertise available if needed.”
- “From the beginning, frame the tasks assigned to the Workgroup in the context of all other amendments that may impact OR affect the decisions made by the Workgroup.”
- “Simplify; shorten the process.”
- “More time- as in calendar days, not necessarily meetings.”
- “More background information.”
- “Workgroup members should be present and engage other fishermen at public meetings.”
- “In choosing Workgroup members, send an application to every permit holder and dealer. After reviewing applications and choosing Workgroup members, follow up on those that were not chosen so that they can follow the process and be present at open workshops.”